

JCHA-4 4Way Waterproof/Weatherproof Distribution board IP65

IP Rated	IP 65
Insulation	Class II
Material	Polycarbonate & ABS (Flame retardant)
Shock resistance	IK10
Protection against chemicals and weather conditions	Water/saline solutions/acids/basics/mineral oils/UV rays
Operating temperature	-25°C~+100°C
Nominal insulation voltage	1000 V AC - 1500V DC

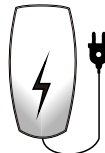

JCHA-4



ideal for EV charger installation

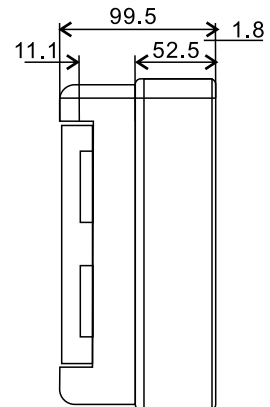
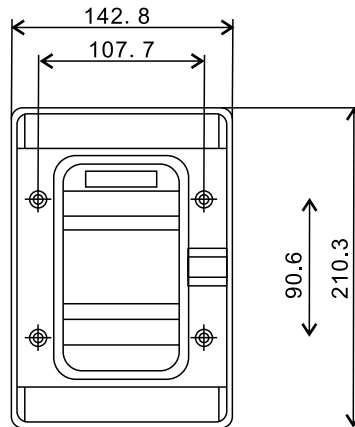

JCHA-8 8Way Waterproof/Weatherproof Distribution board IP65

IP Rated	IP 65
Insulation	Class II
Material	Polycarbonate & ABS (Flame retardant)
Shock resistance	IK10
Protection against chemicals and weather conditions	Water/saline solutions/acids/basics/mineral oils/UV rays
Operating temperature	-25°C~+100°C
Nominal insulation voltage	1000 V AC - 1500V DC



JCHA-8

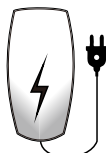

ideal for EV charger installation

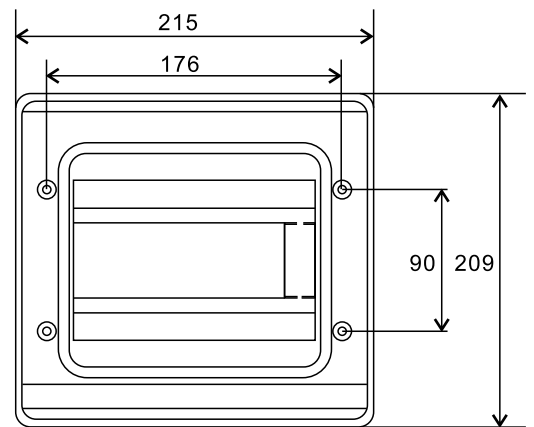
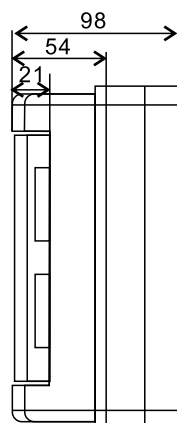

JCHA-12 12Way Waterproof/Weatherproof Distribution board IP65

IP Rated	IP 65
Insulation	Class II
Material	Polycarbonate & ABS (Flame retardant)
Shock resistance	IK10
Protection against chemicals and weather conditions	Water/saline solutions/acids/basics/mineral oils/UV rays
Operating temperature	-25°C~+100°C
Nominal insulation voltage	1000 V AC - 1500V DC



JCHA-12

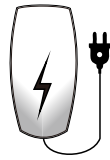

ideal for EV charger installation

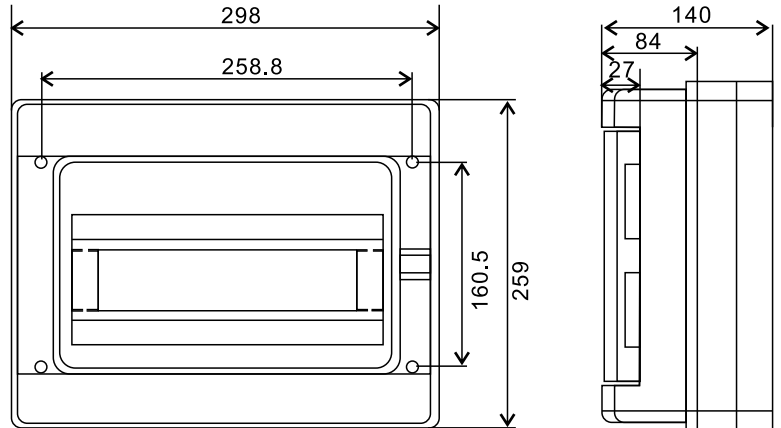

JCHA-18 18Way Waterproof/Weatherproof Distribution board IP65

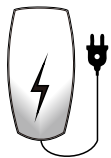

ideal for EV charger installation

IP Rated	IP 65
Insulation	Class II
Material	Polycarbonate & ABS (Flame retardant)
Shock resistance	IK10
Protection against chemicals and weather conditions	Water/saline solutions/acids/basics/mineral oils/UV rays
Operating temperature	-25°C~+100°C
Nominal insulation voltage	1000 V AC - 1500V DC

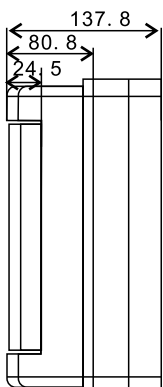

JCHA-18

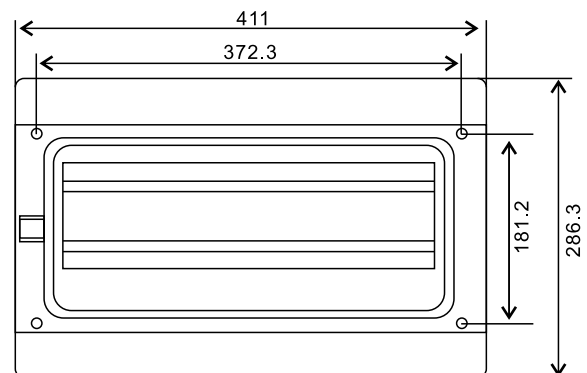

JCHA-26 26Way Waterproof/Weatherproof Distribution board IP65

IP Rated	IP 65
Insulation	Class II
Material	Polycarbonate & ABS (Flame retardant)
Shock resistance	IK10
Protection against chemicals and weather conditions	Water/saline solutions/acids/basics/mineral oils/UV rays
Operating temperature	-25°C~+100°C
Nominal insulation voltage	1000 V AC - 1500V DC

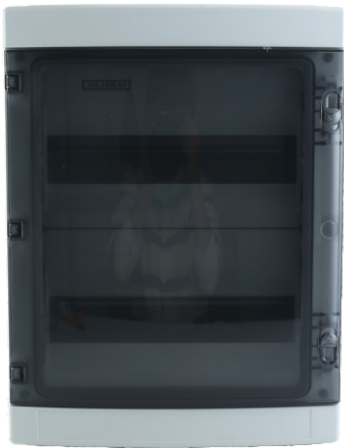

JCHA-26

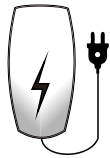

ideal for EV charger installation

